

Interface Control Document for Safeguard Units

September 2019

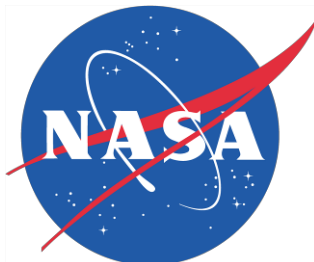

Title: SafeGuard/SMART System Interface Document	Page 2 of 25
Document No: SMART-04-002	Version: Rev 1.0

Table of Contents

1. Introduction	4
1.1.Scope	4
1.2.SafeGuard Overview	4
1.2.1. System Design and Functionality	7
2. Mechanical Interface	9
2.1.Mechanical Alignment and Mounting	9
2.2.Mass	10
2.3.Dimensions and Envelopes	10
2.4.SMART Physical Connector Locations	11
3. Electrical Interfaces	12
3.1.Input Power	12
3.1.1. Optional TCW Integrated Back-up Battery System	12
3.2.External Connectors	12
3.2.1. J1 Input Power Connector.....	13
3.2.2. J2 Secondary Nav Connector.....	14
3.2.3. J3 Relay/Output Connector.....	15
3.2.4. J4 Ethernet Connector.....	16
3.2.5. J5 GPS Antenna Connector	17
4. Data Interfaces	17
4.1.Autopilot Serial UART	17
4.2.Ground System Ethernet Interface	23
4.2.1. TCP/IP Socket Protocol Responsibilities.....	23

Figures

Figure 1.1: SafeGuard Boundaries	5
Figure 1.2: SafeGuard Lateral Boundary Calculations	6
Figure 2.1: SafeGuard System Dimensions and Coordinate Reference.....	9
Figure 2.2: SafeGuard Enclosure Overall View.....	10
Figure 2.3: SafeGuard Mounting Hole Pattern.....	11
Figure 2.4: SafeGuard Connector Locations (-Y View)	11
Figure 3.1: SafeGuard PUD Contact Specification.....	13
Figure 3.2: SafeGuard PUD Connector Specification.....	14

Tables

Table 3.1: Avionics Enclosure Connectors	12
Table 3.2 SafeGuard Input Power Specification	12
Table 3.3 SafeGuard J1 Input Power Connector Pin Assignment.....	13
Table 3.4 SafeGuard Enclosure J2 Secondary Nav Connector Pin Assignment.....	15
Table 3.5 SafeGuard Enclosure J3 Relay/Output Connector Pin Assignment.....	16
Table 3.6 SafeGuard Ethernet J4 Ethernet Connector Pin Assignment	16
Table 3.7 SafeGuard Enclosure J5 Antenna Connector Pin Assignment.....	17

Title: SafeGuard/SMART System Interface Document	Page 3 of 25
Document No: SMART-04-002	Version: Rev 1.0

Table 4.1: Autopilot 3.3V TTL Serial Interface Configuration 18
Table 4.2: Autopilot Telemetry Packet 18

Title: SafeGuard/SMART System Interface Document	Page 4 of 25
Document No: SMART-04-002	Version: Rev 1.0

1. Introduction

1.1. *Scope*

This document provides a description of the SafeGuard system external interfaces for those planning to integrate a SafeGuard unit onto an aircraft. SafeGuard refers to the overall system, and SMART refers to the NASA Class B software that performs the geofencing algorithms and interfaces to the hardware to generate output signals. The enclosure and mechanical mounting are described in section 2. The document also describes the electrical interfaces and communications between the following subsystems:

- External Power
 - Main Power Input
 - Battery Backup (optional)
- Primary Navigation Unit
 - Power
 - Serial Interface
- Secondary Navigation Unit
 - Power
 - Serial Interface
- Relay Outputs
- Ground System Interfaces
 - Ethernet – For configuring the system before flight and off-loading data after flight
 - Serial Console Port – For debugging

1.2. *SafeGuard Overview*

SafeGuard is an onboard system that uses real-time data about the position of a UAV to determine its proximity to a set of pre-defined and pre-loaded lateral boundaries and an altitude limit. Lateral boundaries are defined by a single Stay-In zone, and if desired, one or more Stay-Out zones (See Figure 1.1). These geo-spatial boundaries may be based upon established "no-fly" zones (much like existing aeronautical charts depicting airspace boundaries), or may be created arbitrarily by the UAV operator for a specific mission.

Title: SafeGuard/SMART System Interface Document	Page 5 of 25
Document No: SMART-04-002	Version: Rev 1.0

Figure 1.1: SafeGuard Boundaries

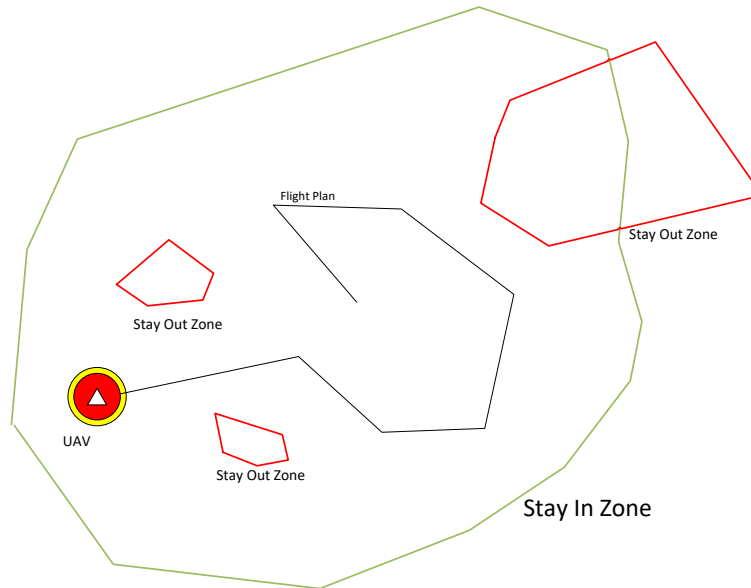

During flight, the Safeguard System uses the vehicle position, velocity, and estimates of associated errors, to determine if the vehicle is within the defined Stay-In boundary and outside any and all defined Stay-Out boundaries (See Figure 1.2). The system will also continuously track and predict whether any boundaries will be violated based on thresholds set by the operator as well as the vehicle's ballistic trajectory (in the case of sudden power loss).

The SafeGuard monitoring solutions are determined at 5 Hz (every 200 mSec). Two solutions (signals) are output.

- (1) A terminate signal is generated when/if the system determines that a Stay-in, Stay-Out, or altitude limit will be breached if immediate action (e.g. cutting power) is not taken. Once this signal is active, there is no means to de-activate it (i.e. it latches 'on'). It can only be reset after flight, as a part of configuration and setup. If a flight termination policy and function is not to be implemented by the operator, this signal may be left unconnected/unused.
- (2) A warning signal is generated prior to the terminate signal to indicate to the receiver of the signal (e.g. the autopilot, a remote pilot via telemetry link, or a simple audio/visual indicator) that there will be breach if the vehicle continues on its current course. The amount of time between triggering the warning and terminate signals can be set by the operator during pre-flight configuration and setup. Unlike the termination signal, the warning signal clears (resets) when the system determines the vehicle is no longer approaching a Stay-In, Stay-Out, or

altitude limit (i.e. the autopilot or pilot has slowed and/or maneuvered the vehicle appropriately).

Figure 1.2: SafeGuard Lateral Boundary Calculations

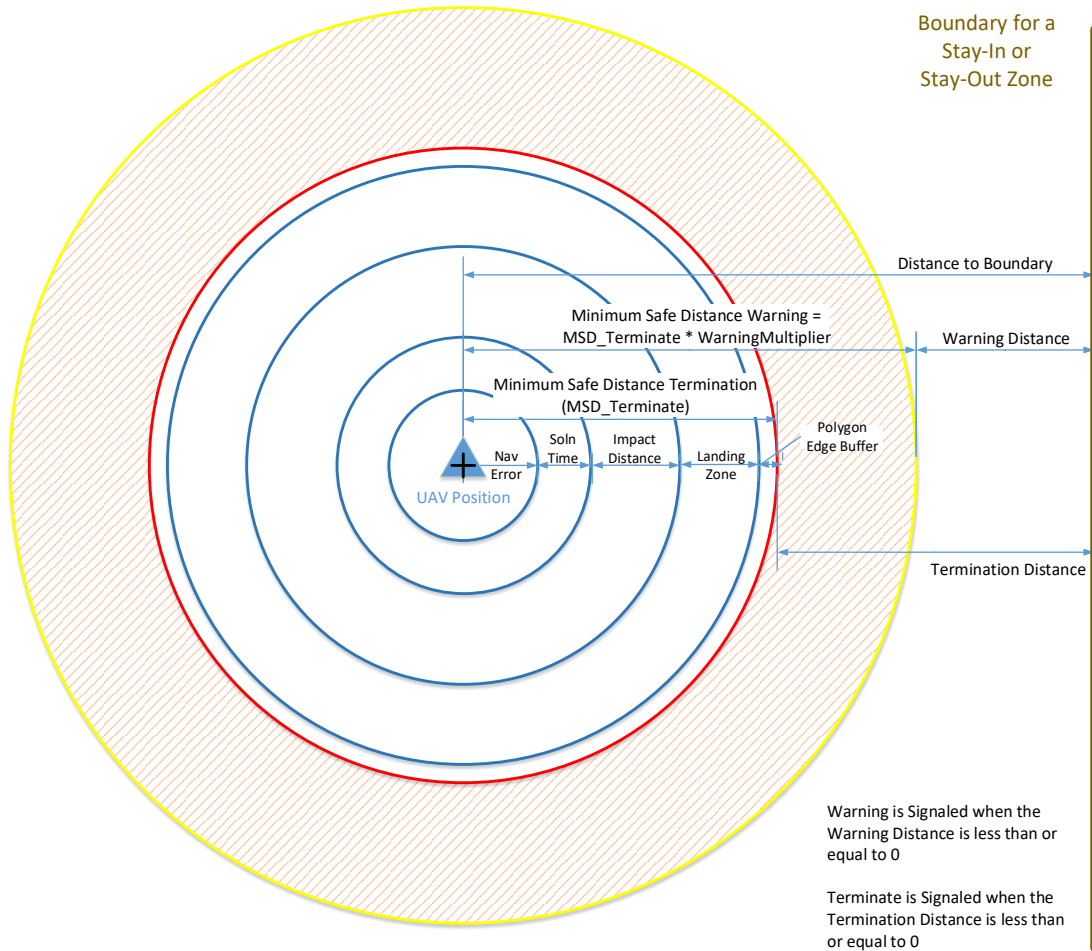

Definition of Terms used in Figure 1.2:

- Nav Error – Error in the navigation position solution provided by the primary and secondary navigation units.
- Solution Time – This component accounts for a maximum lateral acceleration of the vehicle over the time period from when the navigation sensor data was sampled to a time in the future which guarantees another solution will have

Title: SafeGuard/SMART System Interface Document	Page 7 of 25
Document No: SMART-04-002	Version: Rev 1.0

been produced or the system will have terminated. The maximum velocity computed for this element is used for determining the impact distance.

- Impact Distance – The distance the vehicle could travel if the flight was terminated. This value is used in conjunction with a Landing Zone buffer value to determine when the terminate signal should be activated to prevent breaching a boundary.
- Landing Zone – This is an operator-defined value that provides a fixed buffer at each Stay-In and Stay-Out boundary, helping to assure that a terminated flight will not breach a boundary.
- Polygon Edge Buffer – This is a fixed distance representing the thickness of a boundary. This buffer prevents floating-point math from causing solution errors when a solution is close to a boundary.

1.2.1. System Design and Functionality

The SafeGuard system was designed to meet the following system characteristics:

- The system operates independently of the UAV's operating system, autopilot and power.
- The system is sufficiently lightweight to be suitable for most UAVs.
- Algorithms for detecting boundary conditions have been formally verified.
- The system can optionally accept and evaluate a flight plan to determine prior-to-flight if there will be excursions (breaches).
- The system may optionally provide data throughout the flight to the UAV regarding the position of the UAV relative to the buffers and no-fly-zones. Note, this requires additional integration with a telemetry link.

The SafeGuard system performs the following functions:

- Receive up to 20Hz data from a primary Navigation unit. Data is not used if packet integrity checks fail. A Fault is signaled if data quality checks fail. The primary navigation unit is internal to the system.
- An external secondary Navigation unit must be connected to support Nav system integrity checking. Safeguard can receive up to 20Hz data from this secondary unit. As with the primary unit, the data is not used if packet integrity checks fail and a Fault is signaled if data quality checks fail. Two types of secondary navigation units are currently supported. Others may be supportable as long as

Title: SafeGuard/SMART System Interface Document	Page 8 of 25
Document No: SMART-04-002	Version: Rev 1.0

appropriate data formatting and signaling is employed when connecting to Safeguard's external Navigation system port.

- Before flight,
 - System configuration files are checked for validity. Any errors detected will generate a fault preventing the system from transitioning to operational mode.
 - Stay-In and Stay-Out polygon boundaries are checked for validity. Any errors detected will generate a fault preventing the system from transitioning to operational mode.
 - A Flight Plan can be checked against the Stay-In and Stay-Out boundaries. Any breach of the Stay-In or Stay-Out boundary will generate a fault preventing the system from transitioning to operational mode. A flight plan is not required for Safeguard to function.
- During flight, the following are generated and evaluated at 5Hz (every 200 mSec).
 - The primary and secondary Navigation solutions are compared as a quality check. Divergence of these solutions will cause the termination signal to be activated.
 - The current vehicle state (position, velocity) and max vehicle acceleration are used to determine the solution time error, impact distance and impact altitude.
 - As described in section 1.2, warning and/or termination signal states are computed.
 - Hardware and software watchdog timers ensure solutions are being computed at the 5Hz rate. If any software watchdog timer elapses, a termination is signaled. If the hardware watchdog elapses, a hardware reset occurs (also resulting in termination being signaled). Once the termination is signaled, it remains latched (even after a reset).
- All data is logged to onboard flash memory. This includes the data provided by the primary and secondary navigation units, the solution states at 5Hz, and 1Hz telemetry data.
- Generates a telemetry packet at 5Hz that can be sent via a serial interface to the autopilot or other onboard device (e.g. telemetry link). This packet contains the solution states as well as the state of the two output relays (warning and terminate).

Title: SafeGuard/SMART System Interface Document	Page 9 of 25
Document No: SMART-04-002	Version: Rev 1.0

2. Mechanical Interface

2.1. Mechanical Alignment and Mounting

The top of the SafeGuard enclosure provides markings for the internal navigation system coordinate reference frame (see Figure 2.1). The tick marks at the edges of the box define the intersection of the X and Y axes for the primary navigation unit (Z axis is defined by the right-hand rule, out the top of the enclosure).

Figure 2.1: SafeGuard System Dimensions and Coordinate Reference

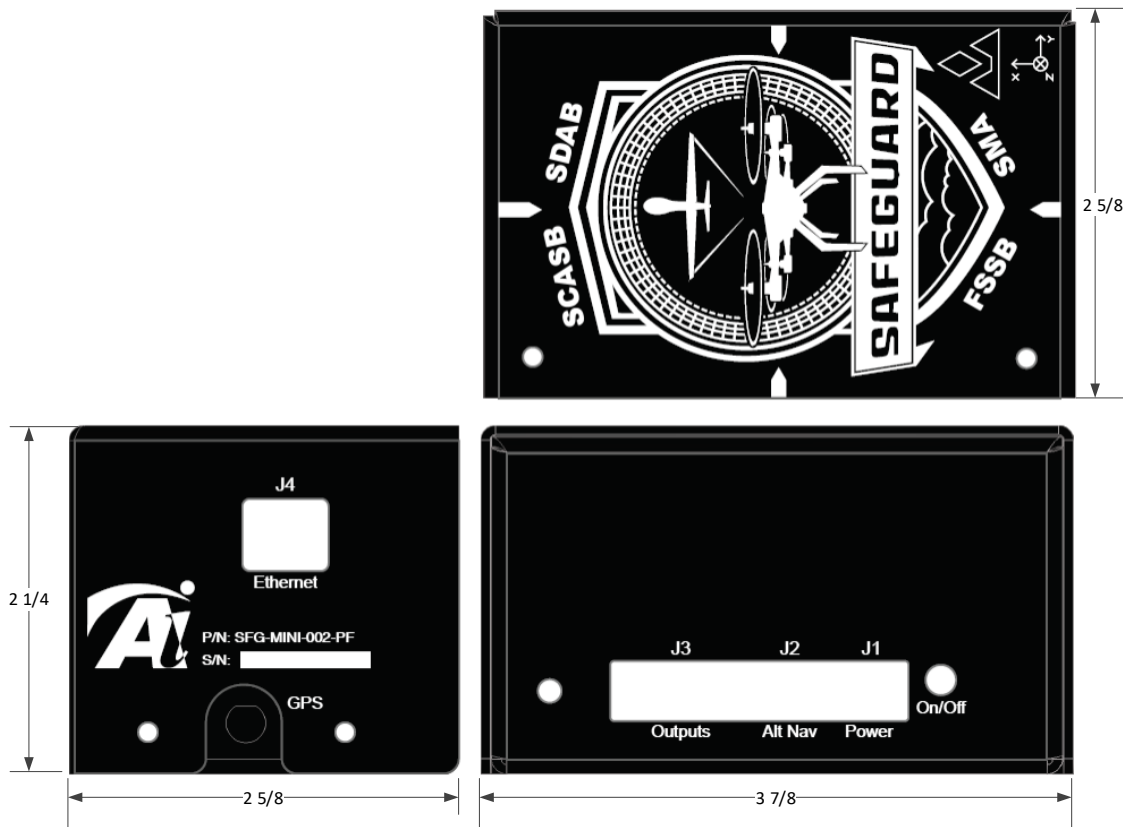

Title: SafeGuard/SMART System Interface Document	Page 10 of 25
Document No: SMART-04-002	Version: Rev 1.0

An overall system view is shown in Figure 2.2.

Figure 2.2: SafeGuard Enclosure Overall View



2.2. Mass

The SafeGuard system mass is 0.7 lbs. This is the mass of the enclosure and its contents and does not include external harnessing required for integrating the system onto a UAV.

2.3. Dimensions and Envelopes

The system envelope is 2 1/4 x 2 5/8 x 3 7/8 inches as shown on the drawing in Figure 2.1. The enclosure provides threaded inserts that can be used to mount the SafeGuard unit to a plate using a through-hole 4-40 threaded fastener. The hole pattern for the threaded mounting inserts is shown in Figure 2.3.

Title: SafeGuard/SMART System Interface Document	Page 11 of 25
Document No: SMART-04-002	Version: Rev 1.0

Figure 2.3: SafeGuard Mounting Hole Pattern

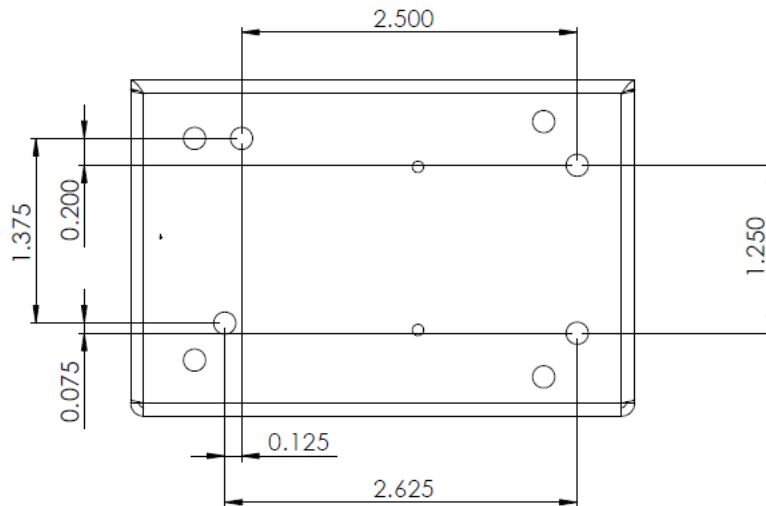

2.4. SMART Physical Connector Locations

The SMART system connector locations are shown in Figure 2.4 below.

Figure 2.4: SafeGuard Connector Locations (-Y View)

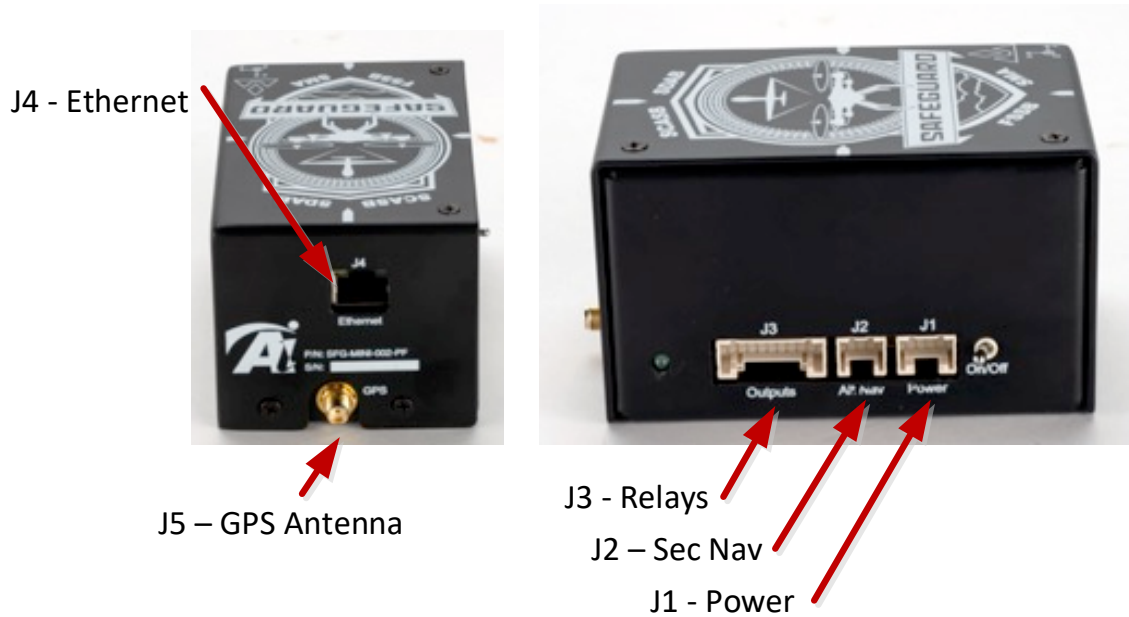

Title: SafeGuard/SMART System Interface Document	Page 12 of 25
Document No: SMART-04-002	Version: Rev 1.0

3. Electrical Interfaces

The connector, pinouts, and signal definitions for each connector on the SafeGuard enclosure are described in the following sections. The SafeGuard enclosure includes five (5) interface connectors listed in Table 3.1. The definition of each connector is described in the following sections.

Table 3.1: Avionics Enclosure Connectors

Identification	Description
J1	Power
J2	Secondary Navigation (Sec Nav)
J3	Outputs/Relays
J4	Ethernet
J5	GPS Antenna

3.1. Input Power

Table 3.2 provides the nominal power consumption for Safeguard. The system will operate over a wide temperature range. When setup with the optional battery backup, the system operates from system power until system power drops below the backup battery voltage. Power for the secondary navigation system is not considered here. Power for the secondary navigation unit is provided on connector J2 and can be used as long as the unit consumes less than 2 Amps continuous power.

Table 3.2 SafeGuard Input Power Specification

	Input Voltage Range (VDC)	Power Consumption @ 13 Vdc (A)	Power Consumption @ 12 Vdc (A)
SafeGuard Unit	6 – 17	0.20	0.22

3.1.1. Optional TCW Integrated Back-up Battery System

The internal CPU has been designed to receive battery info and low voltage signals from a specific battery backup system (TCW IBBS). The low voltage signal indicates when the system is operating from the backup battery (as opposed to vehicle power). The SMART software monitors the IBBS low voltage signal and can be configured to signal a fault when the system is operating from the backup battery.

3.2. External Connectors

This section defines the pinouts for the external interface connectors. In many cases, a

Title: SafeGuard/SMART System Interface Document	Page 13 of 25
Document No: SMART-04-002	Version: Rev 1.0

harness is provided with the unit.

3.2.1. J1 Input Power Connector

The J1 connector is used for input power from an external power source. The connector also provides for signals from an optional TCW Technologies Integrated Back-up Battery System. The signal and pin assignments are shown in Table 3.3 below. Contact and connector information (for JST PUD connectors) are shown in Figure 3.1 and Figure 3.2 (respectively).

Table 3.3 SafeGuard J1 Input Power Connector Pin Assignment

SafeGuard J01 – Power	
Enclosure Connector:	J1 – PUD 10S (S10B-PUDSS-1)
Mating Harness Connector	P1 – PUD 10P (PUDP-10V-S)
Insert	22-26 AWG Contacts
Pin	Signal
1	Input Power
2	Internal Use Only
3	Input Power Return
4	Internal Use Only
5	Low Voltage Warning (TCW IBBS)
6	Battery Info (TCW IBBS)
7	Ground Reference (IBBS Battery Enable)
8	Internal Use Only
9	Internal Use Only
10	Internal Use Only

Figure 3.1: SafeGuard PUD Contact Specification

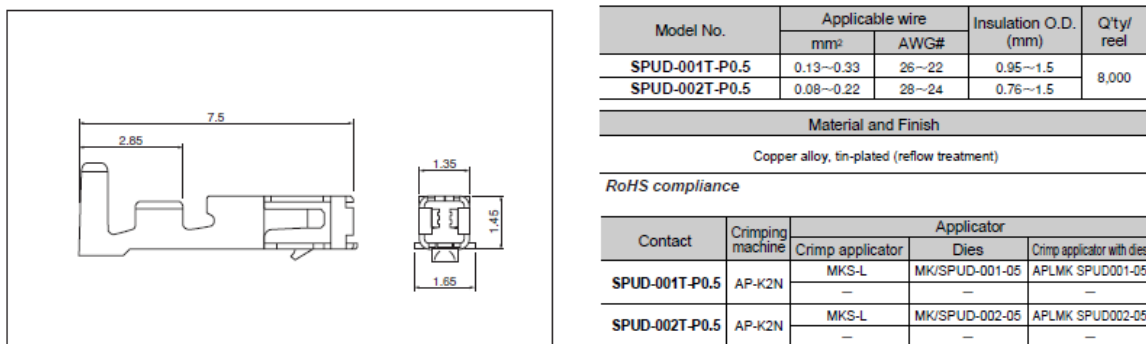
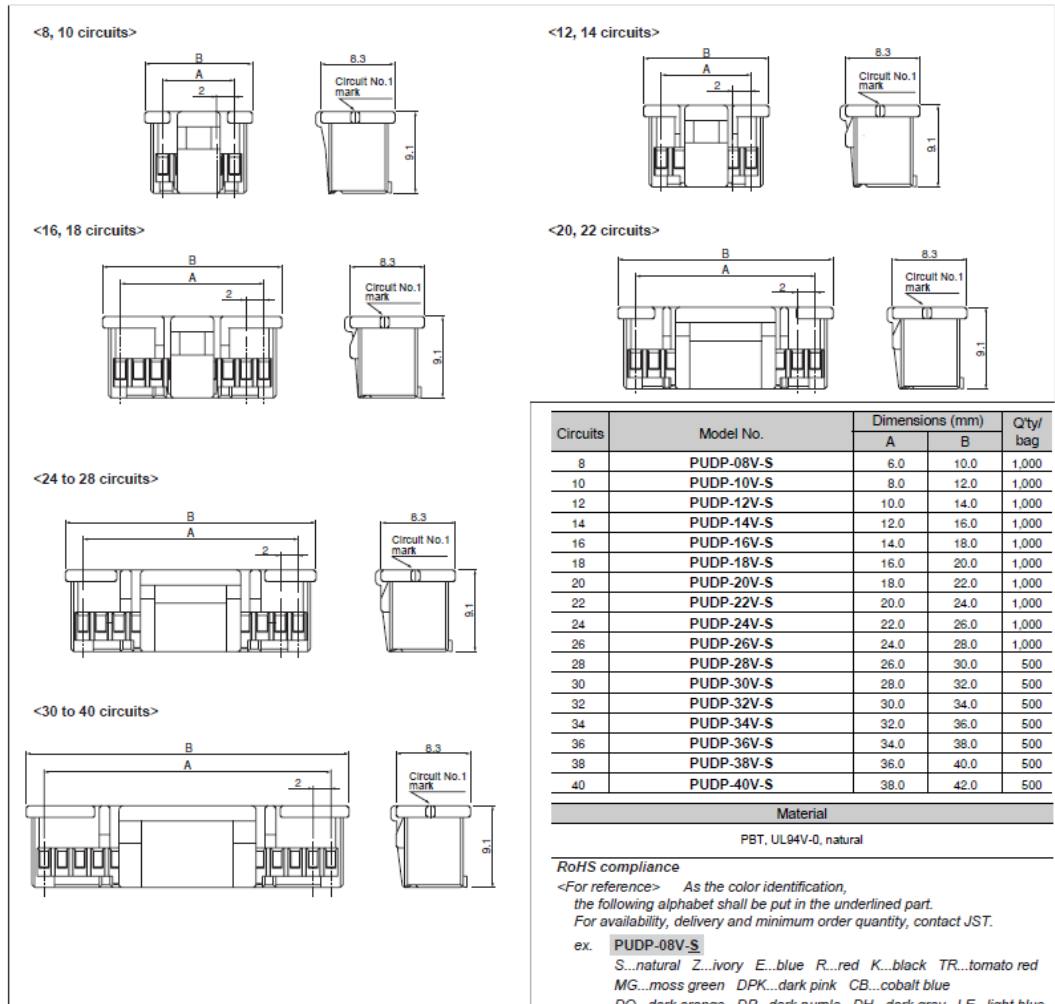

Figure 3.2: SafeGuard PUD Connector Specification



3.2.2. J2 Secondary Nav Connector

The J2 connector provides power and serial data interfaces to the secondary navigation unit. The signal and pin assignments for the J2 connector are shown in Table 3.4 below. Contact and connector information (for JST PUD connectors) are shown in Figure 3.1 and Figure 3.2 (respectively). A cable to the supplied secondary navigation unit should be included with the SafeGuard system.

Title: SafeGuard/SMART System Interface Document	Page 15 of 25
Document No: SMART-04-002	Version: Rev 1.0

Table 3.4 SafeGuard Enclosure J2 Secondary Nav Connector Pin Assignment

SafeGuard J2 – Secondary Nav	
Adapter Connector:	J2 – PUD 8S (S08B-PUDSS-1)
Mating Harness Connector	P02 – PUD 8P (PUDP-08V-S)
Insert	22-26 AWG Contacts
Pin	Signal
1	Power (+12V)
2	Power Rtn
3	SecNavUartTx (3.3V TTL)
4	SecNavUartRx (3.3V TTL)
5	SecNavUartGnd
6	Internal Use Only
7	Internal Use Only
8	Internal Use Only

3.2.3. J3 Relay/Output Connector

The J3 connector provides the Relay outputs for interfacing to an aircraft autopilot or other onboard device or system. The connector also provides a serial interface for transmitting the autopilot telemetry packet (Tx only). The signal and pin assignments for the J3 connector are shown in Table 3.5 below. Contact and connector information (for JST PUD connectors) are shown in Figure 3.1 and Figure 3.2 (respectively).

The Terminate, Warning, and Fault relays maintain isolation between the SafeGuard system and other aircraft systems. The relay outputs switch whatever voltage the aircraft systems wish to receive (The aircraft provides the voltage or ground to switch). The relays are SZNUD3160 rated to switch 2 Amps at 220VDC.

Title: SafeGuard/SMART System Interface Document	Page 16 of 25
Document No: SMART-04-002	Version: Rev 1.0

Table 3.5 SafeGuard Enclosure J3 Relay/Output Connector Pin Assignment

SafeGuard J03 – Relay Outputs	
Enclosure Connector:	J03 – PUD 20S (S20B-PUDSS-1)
Mating Harness Connector	P03 – PUD 20S (PUDP-20V-S)
Insert	22-26 AWG Contacts
Pin	Signal
1	Relay 1 (Terminate) Common
2	Relay 1 (Terminate) Normally Open
3	Relay 2 (Lateral Warning) Common
4	Relay 2 (Lateral Warning) Normally Open
5	Relay 3 (Fault) Common
6	Relay 3 (Fault) Normally Open
7	Relay 4 (Altitude Warning) Common
8	Relay 4 (Altitude Warning) Normally Open
9	Relay 5 (Bank Angle Warning) Common
10	Relay 5 (Bank Angle Warning) Normally Open
11	Relay 6 (Speed Warning) Common
12	Relay 6 (Speed Warning) Normally Open
13	Relay 7 (Flight Path Warning) Common
14	Relay 7 (Flight Path Warning) Normally Open
15	Internal Use Only
16	Internal Use Only
17	Internal Use Only
18	Internal Use Only
19	Autopilot Serial Tx
20	Autopilot Serial Ground

3.2.4. J4 Ethernet Connector

The J4 connector provides the Ethernet interface for pre-flight or post-flight connection to a ground system computer. The signal and pin assignments for the J4 connector are shown in Table 3.6Error! Reference source not found. below. A standard Ethernet cable is used to interface to the SafeGuard system.

Table 3.6 SafeGuard Ethernet J4 Ethernet Connector Pin Assignment

SafeGuard P05 – Ethernet	
Enclosure Connector:	J4 – Ethernet (Standard RJ-45 Jack)
Mating Harness Connector	P4 – Ethernet (Standard RJ-45 Connector)
Insert	N/A
Pin	Signal
1	Ethernet Tx+
2	Ethernet Tx-
3	Ethernet Rx+
4	Not Connected

Title: SafeGuard/SMART System Interface Document	Page 17 of 25
Document No: SMART-04-002	Version: Rev 1.0

5	Not Connected
6	Ethernet Rx-
7	Not Connected
8	Not Connected

3.2.5. J5 GPS Antenna Connector

The J5 connector provides the GPS Antenna interface for the internal primary navigation unit. The box connector is an SMA female connector. A list of compatible GPS antennas is available on request. The signal and pin assignments for the J5 connector are shown in Table 3.7 below.

Table 3.7 SafeGuard Enclosure J5 Antenna Connector Pin Assignment

SafeGuard J5 – GPS Antenna	
Enclosure Connector:	J5 – SMA Female
Mating Harness Connector	P5 – SMA Male
Insert	N/A
Pin	Signal
1	GPS Antenna +
2	GPS Antenna -
Shield	Shield

4. Data Interfaces

The following sections provide details for the autopilot and ground system data interfaces.

4.1. *Autopilot Serial UART*

The autopilot serial interface is a 3.3V TTL serial interface provided via the J3 connector. It is typically used to transmit autopilot telemetry packets during flight. Autopilot telemetry packets are generated each time the SafeGuard solution is computed (every 200 mSec or 5 Hz). If not signaled within a second (which occurs in configuration mode), the Autopilot packet is generated providing the current system status (without the SafeGuard solution, since one was not computed). The serial port configuration is defined in Table 4.1. The SMART software outputs the packet defined in Table 4.2.

Table 4.1: Autopilot 3.3V TTL Serial Interface Configuration

<p>Serial Command Link Protocol: Tx Only Asynchronous 8 data, 1 start, 1 stop, No parity 115,200 bps data rate Bit order is least significant bit first For multi-byte words, the least significant byte is send first.</p> <p>Frame Size: Telemetry – Fixed packet size (122 bytes).</p> <p>Signal Levels: 3.3V TTL level logic (interfaces must be kept short; less than 3 feet)</p>

Table 4.2: Autopilot Telemetry Packet

Data Type	Description	Data Size (BYTES)	Byte Offset from start of packet	Bit Offset (LSB = 0)	Comments
CCSDS Primary Header					
uint16	First Word	2	0		
	Version	Bit Flags Within the first word of the primary header		13-15	000b
	Type			12	1b
	Secondary Header Flag			11	1b
	APID			0-10	18
uint16	Second Word	2	2		
	Sequence Flags	Bit Flags Within the first word of the secondary header		13-15	11b
	Sequence Number			0-12	
uint16	Packet Length	2	4		115
CCSDS Secondary Header					
uint32	Time Stamp Seconds	4	6		System time seconds
uint32	Time Stamp Subseconds	4	10		System time microseconds
uint16	Status Flags	2	14		
	Reserved	Bit Flags Within the status flags		2-15	0
	Checksum Type Flag			1	0 – Checksum 1 – CRC16
	Checksum Flag			0	1 – indicates a checkwork is included at the end of the packet
AP Packet					
uint32	dataSource	4	16		Source for Packet Information 1 – SC is source for data 2 – NAV is source for data
uint16	IO Control State	2	20		Controlled state of the output discrettes

Title: SafeGuard/SMART System Interface Document	Page 19 of 25
Document No: SMART-04-002	Version: Rev 1.0

Data Type	Description	Data Size (BYTES)	Byte Offset from start of packet	Bit Offset (LSB = 0)	Comments
	outputControlEnable	Bit Field in DIO Status Flags		0	Output Control Enable Relay State
	lateralWarning			1	Lateral Position Warning Relay State
	terminate			2	Terminate Relay State
	fault			3	Fault Relay State
	batteryInfo			4	Battery Info discrete state (Monitor Only)
					Not Used here
	speedWarning			5	Speed Warning Relay State
	bankAngleWarning			6	Bank Angle Warning Relay State
	fltPathWarning			7	Flight Path Warning Relay State
	altitudeWarning			8	Altitude Warning Relay State
	reserved			9-15	Reserved for Future use
uint16	terminateFlags	2	22		State of termination signals
	terminateOutOfStayInBounds	Bit Field in Terminate Flags		0	Terminate Signaled for Outside of Stay In Boundary
	terminateNavHealth			1	Terminate Signaled for health of primary navigation data
	terminateInsideOfStayOutBounds			2	Terminate Signaled for Inside of Stay Out Boundary
	terminateOutOfBoundsAltitude			3	Terminate Signaled for Outside of Altitude Boundary
	terminateInitFailed			4	Terminate Signaled for Initialization failure
	terminateOutOfStayInFence			5	Terminate Signaled for Outside of Stay In Fence (should never occur)
	terminateOutOfStayOutFence			6	Terminate Signaled for Inside of Stay Out Fence (should never occur)
	terminateOutOfAltitudeFence			7	Terminate Signaled for Outside of Altitude Fence (should never occur)
	terminateOverMaxProcessingTime			8	Terminate Signaled for exceedance of maximum SC processing time
	terminateMainTaskExecutionRate			9	Terminate Signaled because SC task did not execute at its task rate
	terminateAlgorithmError			10	Terminate Signaled for algorithm error during SC execution
	terminateNavHealthPosKnowledge			11	Terminate Signaled for divergence of lateral Positions

Title: SafeGuard/SMART System Interface Document	Page 20 of 25
Document No: SMART-04-002	Version: Rev 1.0

Data Type	Description	Data Size (BYTES)	Byte Offset from start of packet	Bit Offset (LSB = 0)	Comments
					between primary and secondary Nav solutions
	terminateNavHealthSecondary			12	Terminate Signaled for health of secondary navigation data
	terminateNavHealthPosKnowledgeAlt			13	Terminate Signaled for divergence of altitude between primary and secondary Nav solutions
	terminateDynamicsAlgorithmError			14	Terminate signaled for vehicle dynamics algorithm error during SC execution
	reserved			15	Reserved for future use
uint16	latWarningFlags	2	24		State of Lateral Position Warning Signals
	warningStayInBoundary	Bit Field in Warning Flags		0	Lateral Warning Signaled for Stay In Boundary
	warningStayOutBoundary	Bit Field in Warning Flags		1	Lateral Warning Signaled for Stay Out Boundary
	reserved	Bit Field in Warning Flags		2-15	Reserved for future use
uint16	altWarningFlags	2	26		State of Altitude Warning Signals
	warningAltitudeBoundary	Bit Field in Warning Flags		0	Warning Signaled for Altitude Boundary
	reserved	Bit Field in Warning Flags		1-15	Reserved for future use
uint16	speedWarningFlags	2	28		State of warning signals
	speedWarningPriNav	Bit Field in Warning Flags		0	Speed Warning Signaled from Primary Navigation Device
	speedWarningSecNav	Bit Field in Warning Flags		1	Speed Warning Signaled from Secondary Navigation Device
	reserved	Bit Field in Warning Flags		2-15	Reserved for future use
uint16	bankAngleWarningFlags	2	30		State of warning signals
	bankAngleWarningPriPitch	Bit Field in Warning Flags		0	Bank Angle Warning Signaled from Primary Navigation Device for pitch
	bankAngleWarningPriRoill	Bit Field in Warning Flags		1	Bank Angle Warning Signaled from Primary Navigation Device for roll
	bankAngleWarningSecPitch	Bit Field in Warning Flags		2	Bank Angle Warning Signaled from Secondary Navigation Device for pitch
	bankAngleWarningSecRoll	Bit Field in Warning Flags		3	Bank Angle Warning Signaled from Secondary Navigation Device for roll
	reserved	Bit Field in Warning Flags		4-15	Reserved for future use
uint16	flightPathWarningFlags	2	32		State of warning signals

Title: SafeGuard/SMART System Interface Document	Page 21 of 25
Document No: SMART-04-002	Version: Rev 1.0

Data Type	Description	Data Size (BYTES)	Byte Offset from start of packet	Bit Offset (LSB = 0)	Comments
	fltPathWarning	Bit Field in Warning Flags		0	Warning Signaled for a flight path
	reserved			1-15	Reserved for future use
uint16	FaultFlags	2	34		
	faultIoMonitor	Bit Field in Fault Flags		0	Fault Signaled for IO monitor, monitor does not match control value (See FEID IO MONITOR)
	faultIoControl			1	Fault Signaled for IO control, error reported when controlling discrete outputs (See FEID IO CONTROL)
	faultSystemReset			2	Fault Signaled for a system Reset (See FEID SYSTEM RESET)
	faultSWInit			3	Fault Signaled for a SW initialization error (See FEID SYSTEM INIT)
	faultSWError			4	Fault Signaled for a SW error (See FEID SW ERROR)
	faultConfigInvalid			5	Fault Signaled for an invalid configuration (See FEID CONFIG)
	faultStorage			6	Fault Signaled for a storage error (See FEID STORAGE)
	faultNavHealth			7	Fault Signaled for a nav health error (See FEID NAV HEALTH)
	faultPriNavData			8	Fault Signaled for a primary Navigation data error (See FEID PRI NAV DATA)
	faultSecNavData			9	Fault Signaled for a secondary Navigation data error (See FEID SEC NAV DATA)
	reserved				Reserved for future use
flt32	Latitude			4	36
flt32	Longitude	4	40		Primary nav system longitude used by SC (radians)
flt32	Altitude	4	44		Primary nav system altitude used by SC (meters)
flt32	velocity	4	48		Primary nav system velocity (X is North in the NED frame) used by SC (meters per second)
flt32	velocity	4	52		Primary nav system velocity (Y is East in the NED frame) used by SC (meters per second)

Title: SafeGuard/SMART System Interface Document	Page 22 of 25
Document No: SMART-04-002	Version: Rev 1.0

Data Type	Description	Data Size (BYTES)	Byte Offset from start of packet	Bit Offset (LSB = 0)	Comments
flt32	velocityZ	4	56		Primary nav system velocity (Z is Down in the NED frame) used by SC (meters per second)
flt32	attitude	4	60		The primary navigation solution roll component of attitude used by SC (radians)
flt32	attitude	4	64		The primary navigation solution pitch component of attitude used by SC (radians)
flt32	attitude	4	68		The primary navigation solution yaw component of attitude used by SC (radians)
flt32	latitudeSec	4	72		Secondary nav system latitude used by SC (radians)
flt32	longitudeSec	4	76		Secondary nav system longitude used by SC (radians)
flt32	altitudeSec	4	80		Secondary nav system altitude used by SC (meters)
flt32	minimumSafeDistance (Only updated when dataSource == SC)	4	84		Minimum safe distance calculated by SC (meters)
flt32	minimumSafeDistanceAltitude (Only updated when dataSource == SC)	4	88		Minimum safe distance altitude calculated by SC (meters)
flt32	differenceFromAltLimit (Only updated when dataSource == SC)	4	92		Distance calculated by SC (meters) from the altitude limit
flt32	distToFlightPlan (Only updated when dataSource == SC)	4	96		The distance to the closest point on the flight path calculated by SC (meters)
flt32	distToStayIn (Only updated when dataSource == SC)	4	100		distance to the closest point on the stay in zone calculated by SC (meters)
flt32	distToStayOut (Only updated when dataSource == SC)	4	104		Distance to the closest point on any stay out zone calculated by SC (meters)
flt32	headingToFlightPlan (Only updated when dataSource == SC)	4	108		The heading leading to the closest point on the flight plan in East North calculated by SC (radians)
flt32	headingToStayIn (Only updated when dataSource == SC)	4	112		The heading leading to the closest point on the stay in zone in East North calculated by SC (radians)
flt32	headingToStayOut (Only updated when dataSource == SC)	4	116		The heading leading to the closest point on the closest stay out zone in East North calculated by SC (radians)
CCSDS Checksum					
uint16	Checksum	2	120		
	Total Packet Size		122	Bytes	

Title: SafeGuard/SMART System Interface Document	Page 23 of 25
Document No: SMART-04-002	Version: Rev 1.0

4.2. Ground System Ethernet Interface

This section defines the data interfaces between the SMART system and the ground system. The ground system interfaces to the SafeGuard system via the J4 Ethernet connector (see Table 3.6**Error! Reference source not found.**). A ground system application can be used to configure and setup the SafeGuard system via this interface prior to flight. The SafeGuard system can also provide telemetry via this interface. The Ethernet interface is also used for retrieving log files after flights.

4.2.1. TCPIP Socket Protocol Responsibilities

The SafeGuard/SMART system is the TCPIP Server requiring the ground station to connect as a TCPIP client. The IP address of the server is 192.168.1.10.

SafeGuard Ground Station Socket Functions:

- Connect as a Client to the SafeGuard Server socket port
 - Port 8001 for Commands and Telemetry
- Re-establish TCPIP socket connections if communications is lost
 - Client is responsible for closing and re-opening the TCPIP connection
 - Client is responsible for re-connecting to socket if the server terminates a connection.

SafeGuard/SMART software Socket Functions:

- Setup TCPIP Socket Server ports
 - Ports 8001 for commands and telemetry
 - Only 1 client can connect to this port at a time.
- Command Packet functions
 - Verify packet CRCs
 - Forward commands for execution
- Telemetry Packet Functions
 - Only CCSDS packets are sent. The System Utilities methods in the software ensure the packets are formatted as expected
 - Verify packets are sent
- Disconnect Client if error is detected
 - If an error in the protocol is detected, the server will disconnect the socket. The client is responsible for re-establishing a new connection if the server disconnects the socket.

Title: SafeGuard/SMART System Interface Document	Page 24 of 25
Document No: SMART-04-002	Version: Rev 1.0

Submitted by:

Approval on file

Thomas A. Johnson
Avionics Lead

Approval on file

Noah Ryan
Software Lead

NASA LaRC Approval:

Approval on file

Chris Thames
Project Manager

Title: SafeGuard/SMART System Interface Document	Page 25 of 25
Document No: SMART-04-002	Version: Rev 1.0

Revision History

Version	Date	Description
Rev 1.0	Sept 2019	Initial Release